

## Elastomer O-Ring Seals

# DS-200

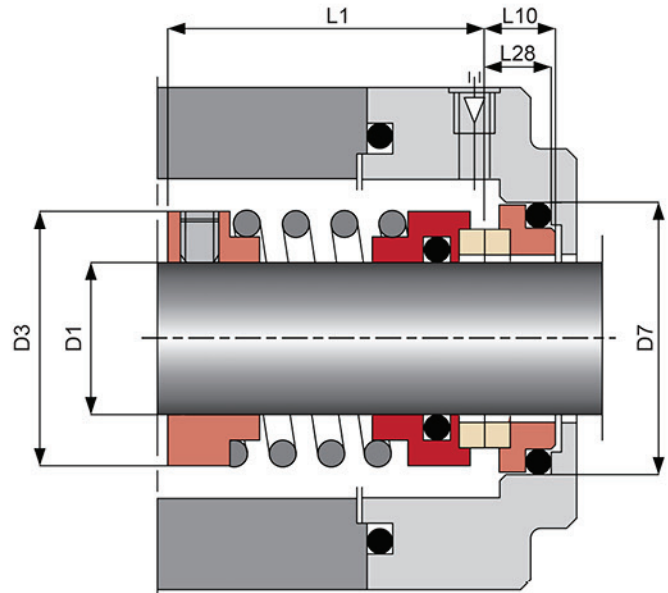

### Applications

- For use in pumps, mixers, blenders, agitators, compressors and other rotary shaft equipment.
- For pulp and paper, petrochemical, food processing, wastewater treatment and other demanding applications.

Type DS-200 mechanical seals are suitable for a wide range of services conditions.

### Standard Materials

- Metal Parts : SUS 316
- Spring : SUS 316
- Rotary Face : Silicon Carbide/Tungsten Carbide/Carbon
- Stationary Face : Silicon Carbide/Tungsten Carbide/Carbon
- Secondary Seals : Fluoroelastomer/Nitrile/Ethylene Propylene

\*(Other configuration of materials also available on request)

### Operating Conditions

- Max. Operating Pressure : 10 kg/cm<sup>2</sup>\*
- Temperature Range : -15 to 200 °
- Max. Rubbing Speed : 20 m/s

\*(Depend on combination of materials)

### Design Features/Benefits

- Non-Clogging, Single Coil Spring will not run foul due to fluid contact.
- Setting-length of spring can be held in position by built-in setter-ring and set screws.
- Sealing faces are precision lapped to provide effective performance with maximum seal life.



# Mechanical Seal Specification

## Engineered Sealing Expertise

### Dimensional Data (mm.)

D1	D3	D7	L1	L10	L28
18	32	33	38	8.5	7.5
20	34	35	38	8.5	7.5
22	36	37	38	8.5	7.5
24	38	39	38	8.5	7.5
25	39	40	38	8.5	7.5
28	42	43	40	7.5	7.5
30	44	45	40	8.5	7.5
32	46	48	40	8.5	7.5
33	47	48	40	8.5	7.5
35	49	50	40	8.5	7.5
38	54	56	45	10.0	9.0
40	56	58	45	10.0	9.0
43	59	61	50	10.0	9.0
45	61	63	50	10.0	9.0
48	64	66	55	10.0	9.0
50	66	70	55	10.0	9.0
53	69	73	58	12.0	11.0
55	71	75	58	12.0	11.0
58	78	78	58	12.0	11.0
60	80	80	60	12.0	11.0
63	83	83	60	12.0	11.0
65	85	85	62	12.0	11.0
68	88	90	62	12.5	11.3
70	90	92	65	12.5	11.3
75	98	97	65	12.5	11.3
80	103	105	70	13.0	12.0
85	108	110	70	15.0	14.0
90	113	115	70	15.0	14.0
95	118	120	75	15.0	14.0
100	123	125	75	15.0	14.0

\* Other sizes are available upon request.