

### Elastomer Bellows Seals

# DS-930

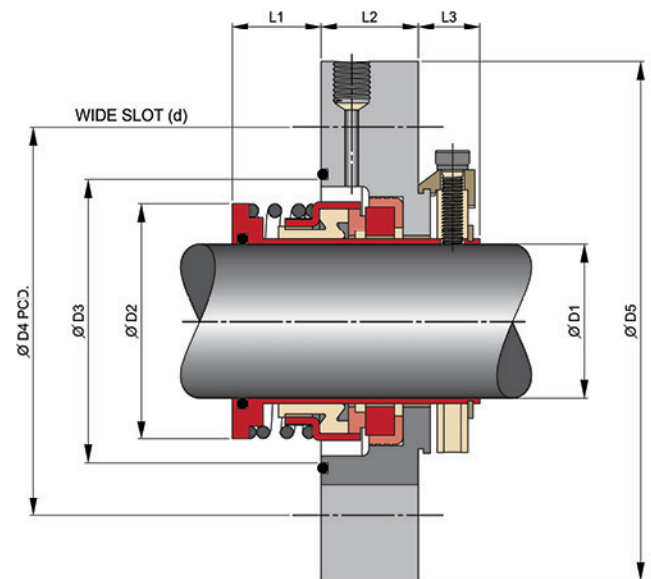

#### Applications

- For use in pumps, compressors and other rotary shaft equipment.
- For pulp and paper, petrochemical, food processing, wastewater treatment and other demanding applications.

Type DS-930 mechanical seals is a general purpose elastomer bellows nonpusher seal.

#### Design Features/Benefits

- Cartridge seal configuration. Easy to install and operate.
- The elastomer bellows seal designed for self-aligning feature compensates for excessive shaft end-play and run-out.
- Non-Clogging, Single Coil Spring will not run foul due to fluid contact.
- Independent of shaft rotating direction.
- A flushing fluid injected into the seal chamber for clean seal faces.

#### Operating Conditions

- Max. Operating Pressure : 30 kg/cm<sup>2</sup> \*
- Temperature Range : -15 to 200 °C \*
- Max. Rubbing Speed : 20 m/s

\*(Depend on combination of materials)

#### Standard Materials

- Metal Parts : SUS 316
- Spring : SUS 316
- Rotary Face : Carbon
- Stationary Face : Ceramic
- Secondary Seals : Nitrile-butadiene Rubber

\*(Other configuration of materials also available on request)

#### Dimensional Data (mm)

Seal size (D1) (mm)	D2	D3	D4	D5	L1	L2	L3	d
20	33.5	38.5	62	85	11.0	23	17	11
22	36.5	41.5	64	87	11.5	23	17	11
25	39.0	44.0	67	90	11.5	23	17	11
28	47.0	52.0	73	96	13.0	24	17	11
30	47.0	52.0	73	96	14.0	24	17	11
32	47.5	52.5	77	100	15.0	24	17	11
35	55.0	60.0	84	110	17.5	24	17	14
38	56.0	61.0	85	110	17.5	24	17	14
40	58.0	63.0	87	113	17.5	25	17	14
45	63.0	68.0	92	118	21.0	25	17	14
50	70.0	76.0	101	127	23.0	25	17	14
55	71.0	82.0	110	136	23.0	25	17	14
60	80.0	88.0	118	147	24.0	25	17	17

\* Other sizes are available upon request.