

## Elastomer Bellows Seals

# DS-BH12/16

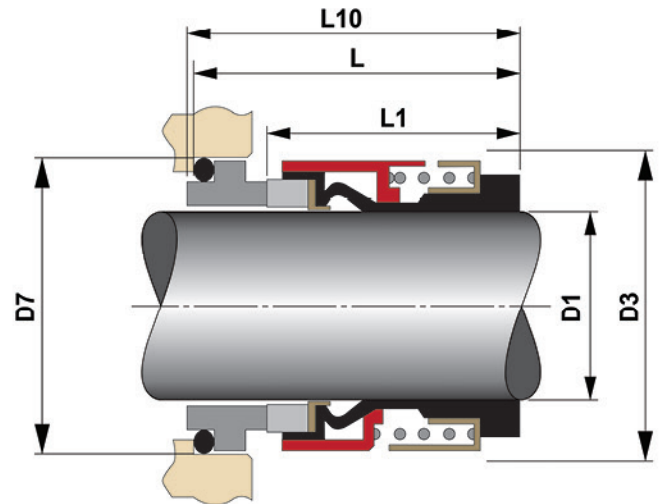

Mechanical seal “DYNAMICA” model DS-BH12/16 is widely used for GRUNDFOS-PUMP.

This mechanical seal is non-clogging component with rigid torque transmission system. This seal type is automatic adjustment fully compensates for normal shaft end play and run-out, seal face wear, and equipment tolerances.

Sealing faces are precision lapped to provide effective performance with maximum seal life. The normal material combination include SiC/SiC/Viton/machined SUS.304 and TC/TC/Viton/machined SUS.304. We also can make changes as customers' requirement or totally design a new type of mechanical seal to meet clients' needs.

They are suitable for use in Grundfos pumps : CH / CHI / CHE / CRK / SPK / TP / AP

### Operating Conditions

- Max. Operating Pressure : 8 kg/cm<sup>2</sup> \*
- Temperature Range : -15 to 200 \*
- Max. Rubbing Speed : 10 m/s

### Standard Materials

- Metal Parts : SUS 316
- Spring : SUS 316
- Rotary Face : Silicon Carbide/Tungsten Carbide
- Stationary Face : Silicon Carbide/  
Tungsten Carbide
- Secondary Seals : Fluoroelastomer/Nitrile

### Dimensional Data (mm.)

Seal size (D1) (mm.)	D3	D7	L1	L	L10
12	22	23	31	39	40.5
16	26	27	32.5	40.5	41.5