

## Suitable for Grundfos Pumps

# DS-CRH22

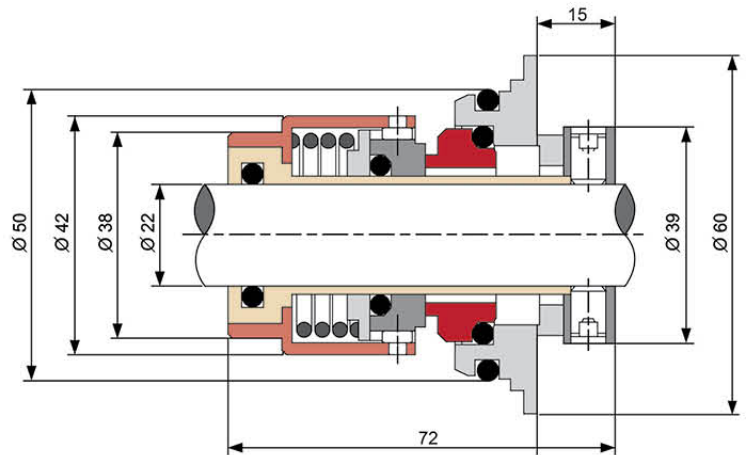

Mechanical seal “DYNAMICA” model DS-CRH22 is widely used for GRUNDFOS-PUMP. Balanced, cartridge O-ring seal unit with rigid torque transmission system. This seal type is assembled in a cartridge unit which makes replacement safe and easy. The balancing makes this O-ring seal type suitable for high-pressure applications.

The normal material combination include SiC/SiC/Viton/machined SUS.304 and TC/TC/Viton/machined SUS.304. We also can make changes as customers' requirement or totally design a new type of mechanical seal to meet clients' needs.

These mechanical seals are used for stainless steel vertical multistage centrifugal pumps. They are suitable for use in Grundfos pumps :  
 CR32 / CRN32 / CR45 / CRN45 / CR64 / CRN64 /  
 CR90 / CRN90 /  
 CR120 / CRN120 / CR150 / CRN150

### Operating Limits

- Pressure:  $\leq 1.0\text{MPa}$
- Speed:  $\leq 10\text{m/s}$
- Temperature:  $-30\text{ }^{\circ}\text{C} \sim +180\text{ }^{\circ}\text{C}$

### Standard Materials

- Rotary Seal Face : Silicon Carbide/  
Tungsten Carbide
- Stationary Seal Face : Silicon Carbide/  
Tungsten Carbide
- Secondary Seal : NBR/VITON
- Spring & Other Metal Parts : SUS304/SUS316